

# DRILL COUNTER BORE TOOL

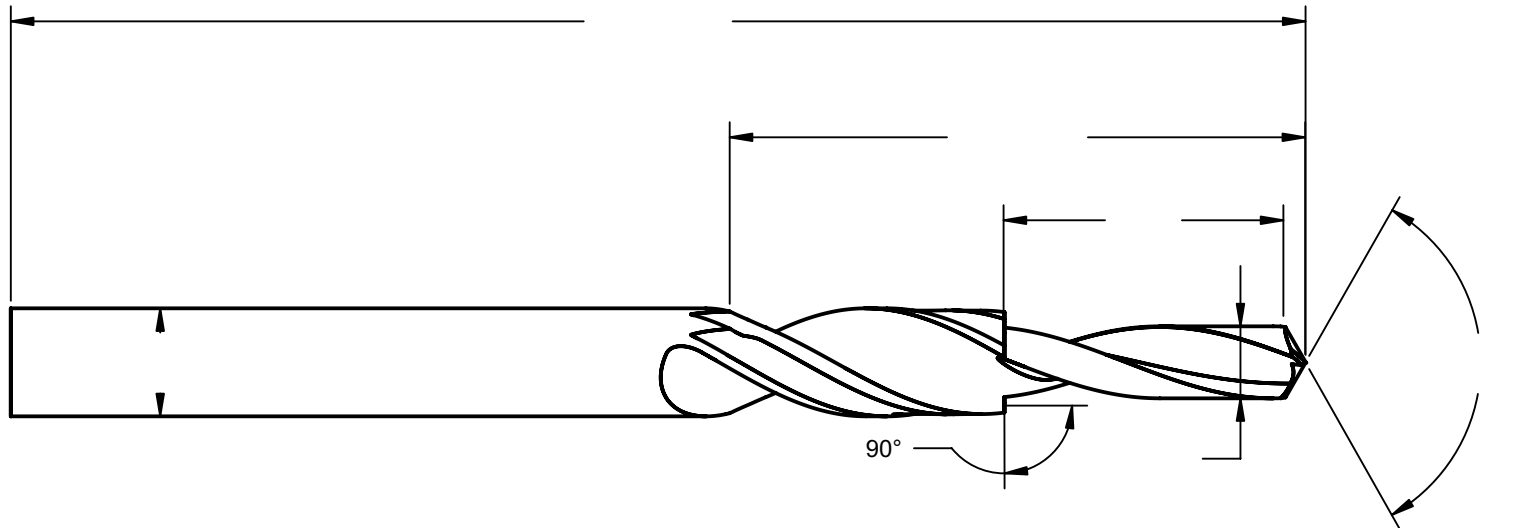

TOLERANCES UNLESS SPECIFIED BY CUSTOMER

.0002" PER INCH  
BACK TAPER FOR  
DRILLS/REAMRES

	+/- .0005
	+/- 10'
.XXXX	+/- .0003
.XXX	+/- .001
.XX	+/- .005
O.A.L	+/- .05

HSS COBALT CARBIDE	# OF FLUTES
MATERIAL BEING CUT	
COATING PREFERENCE: TiN TiCN TiCN-MP TiAlCN TiAlN AlTiN ZrN NANO-tek AlCrN Amorphous Diamond VTI RECOMMEND	



3040 N. Pointer Rd. Appleton, WI 54911  
800.734.2573 | 920.734.2573 | Fax: 920.734.1749  
sales@Valley Tool.net | www.Valley Tool.net

COMPANY YOUR NAME PHONE # EMAIL	
PART#	
DO NOT SCALE	REV: NONE